



For accuracy and professionalism

**New South Wales & Australian Capital Territory**  
Ph: (02) 9603 1205  
rowensw@rowe.com.au

**Queensland**  
Ph: (07) 3376 9411  
roweqld@rowe.com.au

**South Australia & Northern Territory**  
Ph: (08) 8186 0523  
rowesa@rowe.com.au

**Victoria & Tasmania**  
Ph: (03) 9701 7077  
rowevic@rowe.com.au

**Western Australia**  
Ph: (08) 9302 1911  
rowewa@rowe.com.au

www.rowe.com.au



# What is the MABOR difference?

1. Raw magnesite is put through a furnace at the mine site and “dead burned” releasing CO<sub>2</sub>. The waste materials that reveal themselves are manually removed before the pure material is ground and shaped into cupels. This process is crucial as it removes CO<sub>2</sub> and impurities that create cracking during heating and stop the loss of gold samples.
2. Mabor’s process of grinding its magnesite to a uniform size before pressing is another reason why its cupels are superior; porous and slightly cracked cupels cause gold samples to sink between these cracks resulting in low or inaccurate gold assays.

## CUPELS

CUPEL SIZE	UNITS PER CARTON	CARTON DIMENSIONS (cm)			GROSS WEIGHT (kg)
		L	W	H	
8A	200	46.5	24.5	16.0	20.8
8AM	200	46.5	24.5	16.0	21.8
8C	240	38.5	30.2	17.5	22.3
8S	180	45.5	27.8	14.0	20.0
8Y	200	44.5	23.5	15.0	20.2
9	192	42.5	23.0	20.0	21.7
9C	160	42.5	23.0	19.0	20.9
9F	128	43.0	23.5	18.0	18.4
10	140	44.0	26.0	17.0	21.5
11	112	42.0	25.0	20.0	22.7
11A	112	42.0	25.0	20.0	24.2
12	45	42.5	26.5	16.0	20.6
12A	45	42.5	26.5	18.0	23.5
14	16	46.5	25.5	16.0	19.7
15	4	33.5	33.5	14.5	20.0
PC	1	29.5	29.5	17.5	16.6

3. Other manufacturers use a die-press for cupels, making up to 100 at a time leaving those in the centre and side of the press different in their porosity, Mabor individually press each cupel and use a unique binding recipe to ensure each item reaches the highest internal quality controls.

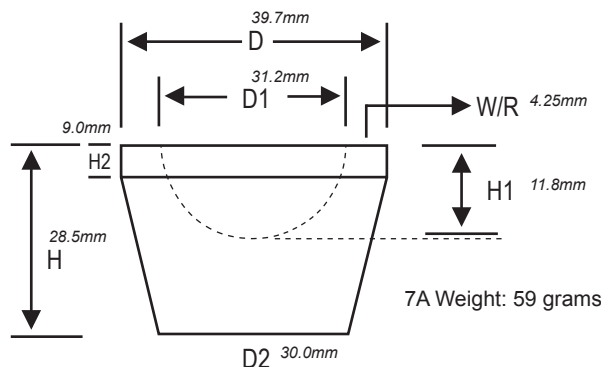

7A Size Cupel Dimensions

- D = Diameter of Cupel
- D1 = Diameter of Cup top Portion
- D2 = Diameter of Base of Cupel
- H = Height of Cupel
- H1 = Depth of Cup
- H2 = Height of Ridge
- W/R = Width of Ridge

4. By taking special care with each item, Mabor’s products consistently last longer and produce lower losses. After the cupels and bullion blocks are pressed they are oven dried at 150°C (not sun-dried), meaning it is not necessary to pre-fire Mabor products, saving time, energy and money.

5. The finishing touch for a Mabor cupel is the individual attention each one receives - prior to shipping any rough edges are smoothed out and all dust vacuumed away leaving less dust for your equipment and staff.



# ROWE SCIENTIFIC

PTY LTD ABN 63 009 437 790

## Mabor Cupels and Bullion Blocks

### CUPELS

CUPEL SIZE	UNITS PER CARTON	CARTON DIMENSIONS (cm)			GROSS WEIGHT
		L	W	H	
1	1440	39.0	23.0	18.0	19.5
2X	1296	39.0	23.0	18.5	17.5
3	1080	39.0	22.5	19.0	18.6
4	819	38.0	21.5	20.0	17.2
4A	900	39.5	27.0	16.0	20.5
5	728	39.5	22.0	19.0	18.5
6	462	39.5	22.5	18.0	18.0
7	300	41.5	22.5	17.0	14.0
PM	720	43.0	23.5	17.0	20.5
6A	300	41.5	23.0	18.0	15.0
7A	300	50.5	23.0	19.5	18.5
7A	420	50.5	30.7	17.0	25.9
7AL	420	50.5	30.7	17.0	24.3
7B	300	42.0	23.0	22.0	21.1
7X	300	42.0	23.0	23.0	23.6
SA	300	42.0	23.0	18.0	17.1
8	240	38.0	29.5	16.0	18.2

*It's how Mabor make their products that make them stand apart from other manufacturers*



Mabor cupels are refined like no other with the company using over 100 years of manufacturing know-how to guide their processing practices for more longer-lasting and reliable products

### BULLION BLOCKS

SIZE	UNITS PER CARTON	CARTON DIMENSIONS (cm)			GROSS WEIGHT (kg)
		L	W	H	
4HB	224	42.0	23.0	18.5	22.8
4SAHB	60	42.0	26.0	13.0	19.8
6HB	120	41.0	24.0	15.5	18.8
6HB (T)	120	43.5	27.0	15.0	22.8
10HB	60	44.0	27.5	13.0	19.2
12HB	105	43.0	21.5	18.0	22.2
12HB (L)	48	38.9	19.9	22.5	19.1
14HB	56	40.0	21.5	19.0	21.7
21HB	42	36.0	25.0	20.0	21.3
24HB	48	35.0	26.5	18.5	20.3
24HB	24	38.9	19.9	22.5	21.0

*When a fire assayer wants an accurate gold analysis they turn to Mabor - used in gold mines all over the world for almost 100 years - including Australia, South Africa, Colorado and Fiji*

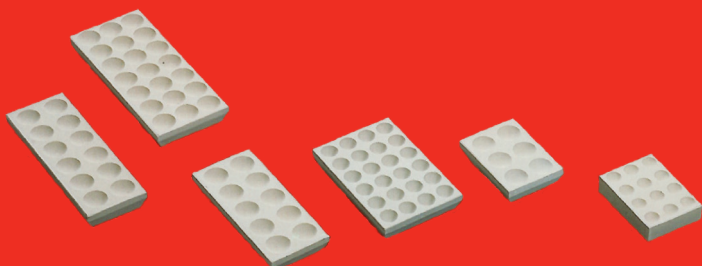

THE MANUFACTURER IS CERTIFIED FOR:  
 ISO 9001 - QUALITY MANAGEMENT SYSTEMS  
 ISO 4001 - ENVIRONMENTAL MANAGEMENT SYSTEMS  
 OHSAS 18001 - OCCUPATIONAL HEALTH AND SAFETY